

MICRO AND NANO MANIPULATION FOR ENGINEERING MANUFACTURE

**S. P. Edwardson¹, W. Perrie¹, C. J. Williams¹, M. Sharp¹, G. Dearden¹,
Z. B. Wang², D. Whitehead², P Crouse², Z. Liu³, L. Li², K. G. Watkins¹**

¹ NWLEC and Laser Group, Department of Engineering, The University of Liverpool, UK;

² NWLEC and Laser Processing Research Centre, School of MACE, The University of Manchester, UK;

³ NWLEC and the Corrosion and Protection Centre, The University of Manchester, Manchester, UK.

Abstract

The newly formed North West Laser Engineering Consortium (NWLEC), a strategic alliance between the Universities of Liverpool and Manchester in the North West of England UK, has an ongoing research programme into micro and nano manipulation techniques for micro-assembly and manufacture. A key area of research is optical trapping. Since their invention just over 20 years ago, optical traps have emerged as a powerful tool with broad-reaching applications in biology, physics and now potentially engineering. Capabilities have evolved from simple manipulation to the application of calibrated forces on—and the measurement of nanometer-level displacements of optically trapped objects. In this paper the principle of operation, the current capabilities and current work in optical trapping for engineering manufacture by NWLEC are detailed.

Keywords: Micro & Nano Technologies, Optical Trapping, Optical Tweezers.

1 Introduction

In recent years the importance of miniaturisation has been growing rapidly as it has become possible to develop devices, components and systems of increasing efficiency and smaller size. In the field of micro and nano processes for the production of such devices and components, laser techniques have emerged as one of the key enabling technologies.

The newly formed North West Laser Engineering Consortium (NWLEC), a strategic alliance between the Universities of Liverpool and Manchester in the North West of England UK, funded by the North West Development Agency (NWDA), has an ongoing research programme in a number of key micro-technology areas. These areas include the use of short pulse lasers for surface texturing, the generation and exploitation of nano-particles and techniques for the manipulation of micro and nano objects for engineering manufacture. More

information can be found at nwlec.org.uk. This paper presents some of the collaborative ongoing research results from the consortium.

The research undertaken by NWLEC seeks to investigate the use of lasers at the forefront of engineering in the fabrication and assembly of these micro and nano components and machines, furthering the understanding of the challenges working at this level of scale in particular where surface effects rather than bulk properties become dominant. It is felt that key to overcoming these challenges is the study of micro and nano object control using optical trapping and of micro and nano fabrication using ultra short pulse laser energy combined with such micro and nano manipulation techniques. The background and state of the art to these areas of interest are presented here as well as the ongoing work by NWLEC in this area.

2 Optical Trapping

Since their invention just over 20 years ago, optical traps have emerged as a powerful non-contact manipulation tool with broad-reaching applications discovered so far in biology and physics. Arthur Ashkin pioneered the field of laser-based optical trapping in the 1980s [1]. Ashkin and co-workers employed optical trapping in a wide-ranging series of experiments from the cooling and trapping of neutral atoms to manipulating live bacteria and viruses. Optical micromanipulation or optical tweezers offer precision positional sensitivity down to the angstrom level, and forces can be measured in the femto Newton regime [2]. This has given insight into many biological macromolecules, in particular molecular motors such as kinesin motion on fixed microtubules and the actin-myosin system. It has also permitted key studies on DNA. Extended two and three-dimensional light patterns create optical potential energy landscapes that may give insight into colloidal dynamics, Brownian motion, create analogs of atomic systems, and even superconductivity. Trapping may move objects of the scale of a large cell, though this is typically quite challenging, and reports have shown trapping of particles of sizes down to 20 nm [3].

Optical tweezers normally employ a near-Gaussian laser and are based around standard microscopes that use a high-numerical-aperture (NA) objective lens. For high-index particles, that is objects whose refractive index exceeds that of their surroundings, the applied light field interaction with the particle consists of a gradient and a scattering force component, and the competition between these two yields stable trapping. **Fig. 1** shows the geometric optical interpretation of light-particle interactions that give rise to transverse (x-y trapping) and axial (z trapping) optical trapping forces in a tightly focused Gaussian beam. Light refracted through a transparent object imparts momentum to the object to balance its change in direction. Optical forces are balanced when the object reaches the centre of the focused beam. [4]

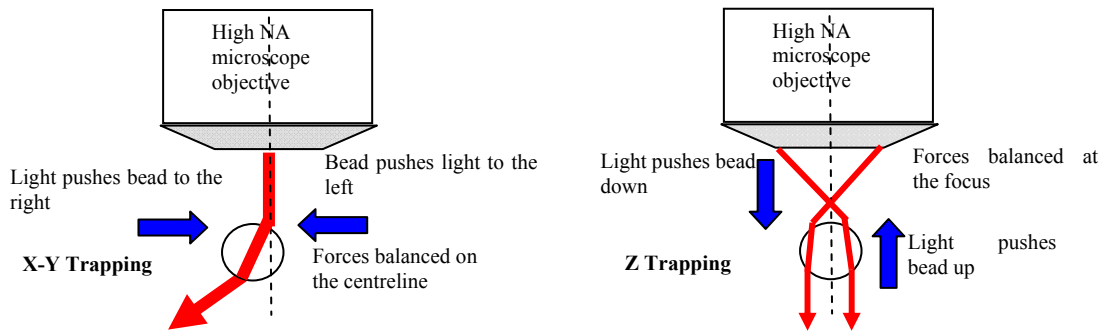

Fig. 1: Schematic of light-bead interaction that gives rise to optical trapping forces in a tightly focused Gaussian laser beam.

When the particle size is substantially less than the wavelength of the irradiating light, the trapped object may be considered as an induced dipole that minimizes its energy in the trapped light field. The electromagnetic field of the light pulls the particle into the brightest part of the beam, where the induced dipole will minimise its energy.

Importantly, virtually all traps operate in a liquid medium where the buoyancy provided simplifies the trapping and damps the particle motion. Trapping has been realized in air, however, in this under-damped regime, attaining good long-term particle stability is an issue [5].

Optical trapping has been largely limited to dielectric (transparent) particles although the stable trapping of metallic (low index) objects maybe possible though this may involve the use of novel beam shaping or advanced trapping geometries.

Activity in optical micromanipulation in the last decade has been driven by advanced trapping geometries [6]. The normal tweezing geometry uses a microscope objective lens and a standard Gaussian laser beam. This arrangement can only provide a single ellipsoidal trap, elongated along the optical (z) axis. These conventional techniques offer little flexibility for tailoring the optical potential in three-dimensional space and dynamic, multiple trapping can only be realised by time multiplexing single traps or the creation of multiple traps.

Multiple traps may be generated in many ways, the simplest being a dual beam trap. A popular and powerful method is the use of acousto-optic deflectors (AODs), which time-share the light beam between each site. Absence from any given site gives the particle an opportunity to diffuse away from its trapped position, which ultimately limits this technique.

Recently, new studies have used holographic or advanced imaging, namely phase-contrast methods, to establish arrays of optical traps. The dynamic projection of holograms and advanced spatial filtering has been demonstrated using a spatial light modulator (SLM) [7,8]. These 'Holographic Optical Tweezers' (HOT) represent an important step in gaining complete flexibility in manipulating multiple particles independently through the creation of

arbitrary optical landscapes. As the spatial light modulator is dynamically reconfigurable in real time, it is possible to adapt the optical landscape in response to changes within the sample [8]. Such SLM devices typically consist of arrays of liquid crystals that may be either optically or electrically addressed (**Fig. 2**). Each pixel can be driven to induce a phase change of $0-2\pi$. A drawback of such systems can be their efficiency in terms of resolution.

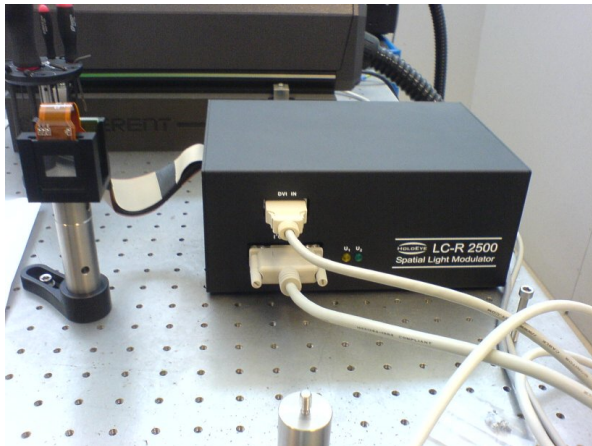

Fig. 2: Example of a Spatial Light Modulator (SLM). Holoeye LC-R 2500. This is a reflective element.

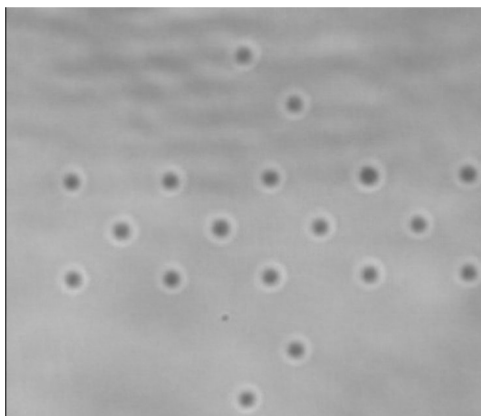

Fig. 3: 5 micron silica spheres in water held in an ordered array using holographic optical tweezer techniques. [7]

In addition to arrays of traps, holographic technology may assist in generating unusual transverse laser modes. The Laguerre-Gaussian light beam is one such example of an unusual propagating light mode of interest that may be generated in this way. Modes such as Laguerre-Gaussian beams may carry both spin and orbital angular momentum, which may be transferred to a particle to make it spin and gyrate. Bessel beams, generated from Gaussian beams are pseudo- ‘nondiffracting’ beams, which have a very narrow rod-like core

maintained over extended distances. This makes it possible to trap multiple particles along the axis of the beam. These modes have been shown to be useful for a number of studies including extended guiding of particles or optical conveyor belt [9].

Research into optical trapping technology has so far had an emphasis on the control of a small number of biological macromolecules, so there is immense scope for expansion of this science into engineering applications. For instance, there is little or no research in the hybrid of trapping and consolidation (fabrication) with a second laser source. Additionally, the realm of multiple traps generated by holographic techniques involving novel light beams is in its infancy. Optical trapping has had a wide and far-reaching impact since its inception. There is little doubt that this technique will maintain its foothold at the leading edge of the biological and colloidal sciences, and undoubtedly reveal more surprises in the detailed understanding of various aspects of nanoscale and microscale science in years to come [4].

3 NWLEC Capability and Ongoing Work

The ongoing research programme by NWLEC on novel laser processes for microtechnology aims to exploit the potential capability of optical trapping for the micro-manipulation of components for engineering manufacture. To this end an optical trapping facility has been designed and built at the Lairdside Laser Engineering Centre (LLEC) in Birkenhead part of the University of Liverpool (**Fig. 4**).

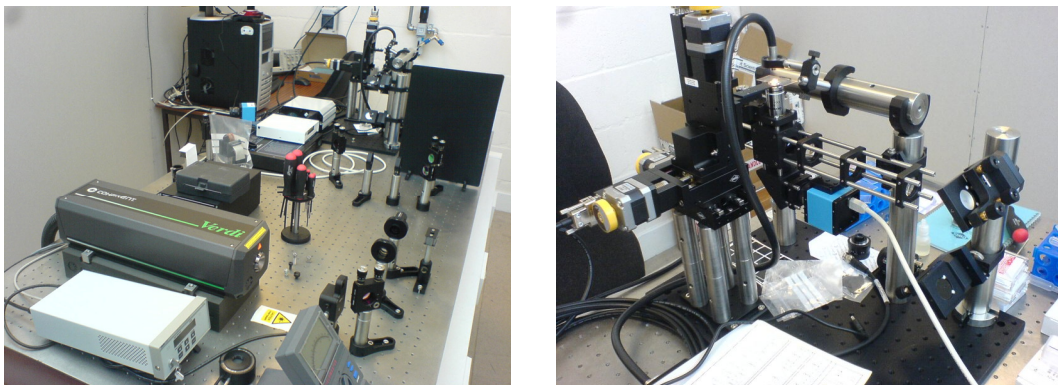

Fig. 4: NWLEC's optical trapping facility

The source laser for the optical tweezers set up is a Coherent Verdi V2 (**Fig. 4**), a CW 2W frequency doubled (532nm) Nd:YVO₄ (vanadate) laser. This is a high quality laser of a single frequency and M^2 of 1 (Gaussian).

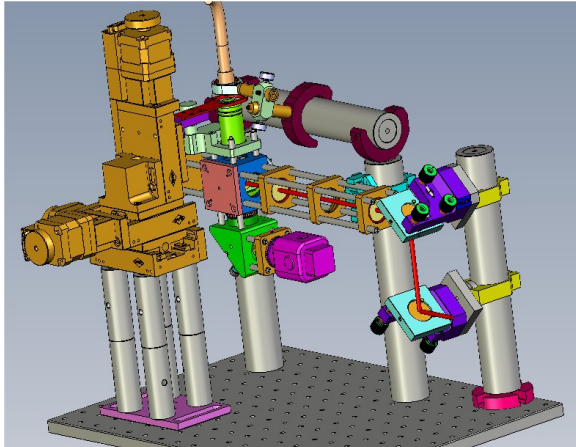

Fig. 5: *Inverted optical tweezers design*

It was decided that rather than build the system around the fixed rigid body of a standard microscope, the system would instead be built from re-configurable standard optical components (**Fig. 4**). An inverted optical tweezers arrangement was constructed to our specification by Elliot Scientific (**Fig. 5**).

In this arrangement the beam is delivered to an inverted video microscope to provide initially a single trapping site. The objective is an Olympus x100 1.25NA oil immersion, index matching gel required (**Fig. 6**).

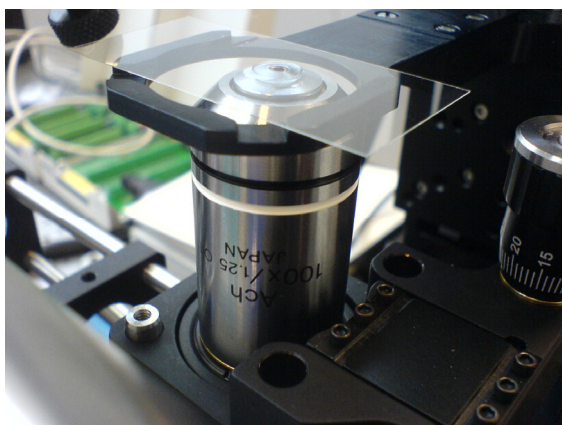

Fig. 6: *High NA inverted microscope objective.*

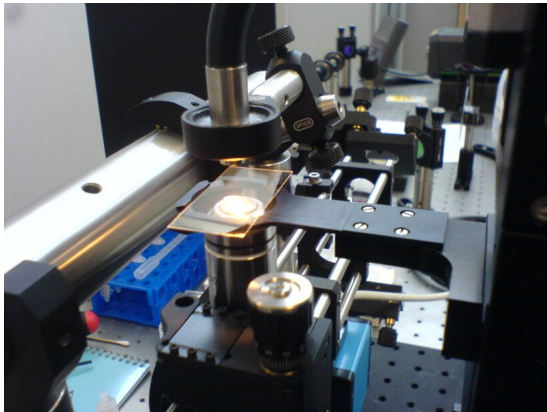

Fig. 7: Sample holding arm and illumination.

Focus control and the position of the sample relative to the trapping site are given by XYZ OWIS 25x25x25mm travel CNC tables controlled under Labview. A (liquid) sample is placed on a coverslip on the sample holder arm shown in **Fig. 7**, this is attached to the CNC tables and is independent of the beam delivery optics. Illumination is provided by a fibre optic illuminator from above (**Fig. 7**). A firewire video camera is used to observe the optical trapping event via a beam splitter and filter.

A telescope is employed in the cage work (**Fig. 4**) to expand the raw beam (~5mm dia.) in order to overfill the input to the microscope objective. This ensures that the tightest possible focus is achieved, it also means that the final turning mirror and the back face of the objective are conjugates.

Initial trapping experiments have taken place using 5 μ m diameter silica beads from Bang Labs Inc. These are supplied in DI water in high concentrations and have to be diluted in order to produce a sufficiently dispersed sample (**Fig. 8**).

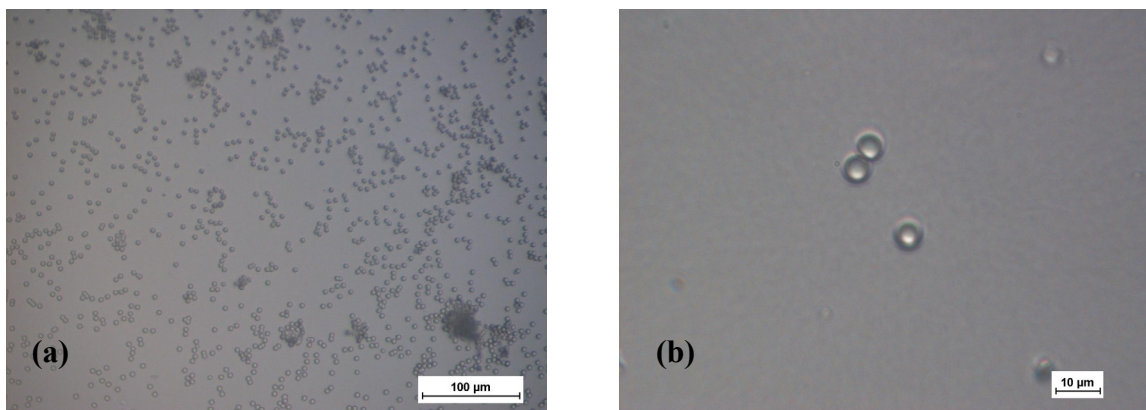

Fig. 8: 5 μ m diameter silica spheres in water a) x20 b)x100.

Optical trapping with this initial single trapping site setup has been possible. A sequence is shown in **Fig. 9** where a lower strength filter on the camera is used so that the laser can be observed.

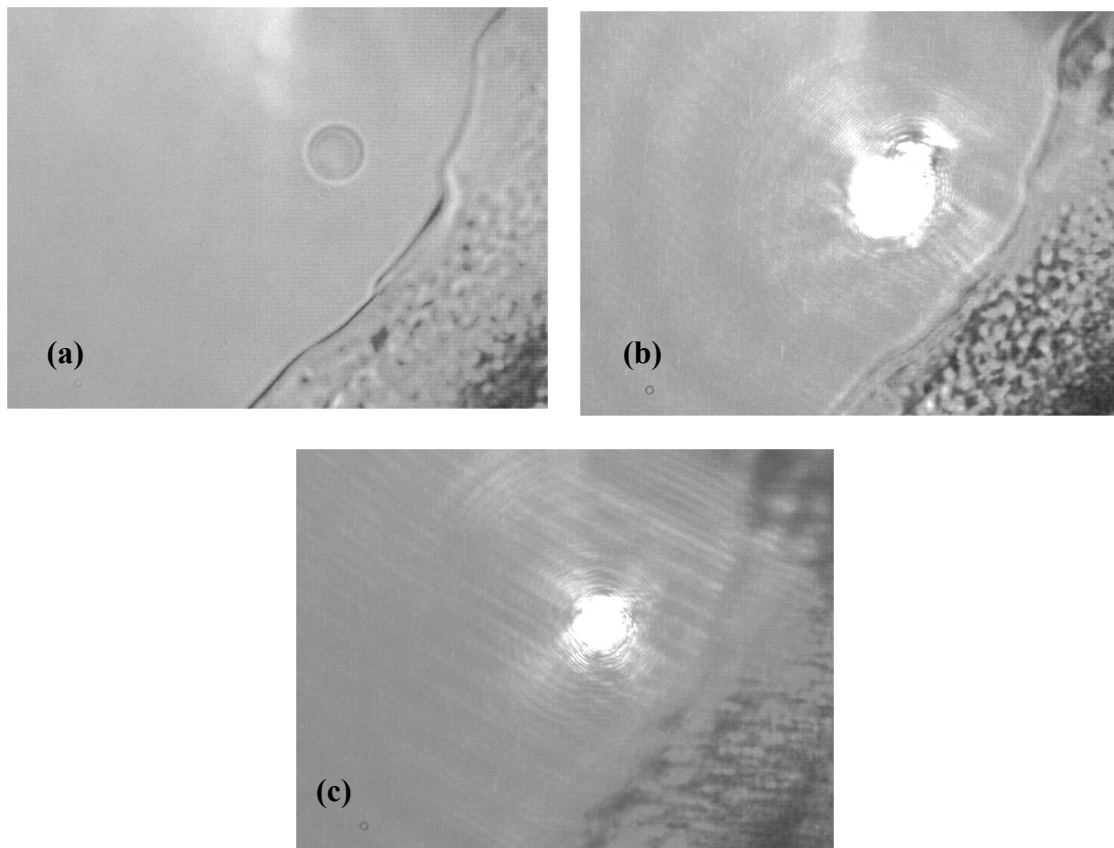

Fig. 9: *Optical trapping sequence of a 5 μ m silica bead in water. a) no laser. b) laser on (~100mW) slightly below bead, refraction through bead observable. c) bead is drawn to the laser and is trapped.*

The area seen on the right hand side in **Fig. 9** is the edge of a round sticker used to contain the liquid on the cover slip.

Fig. 10 shows a sequence where a stronger filter on the camera is used and so it is possible to see the trapping and manipulation of the bead into a useful pocket on the containment sticker.

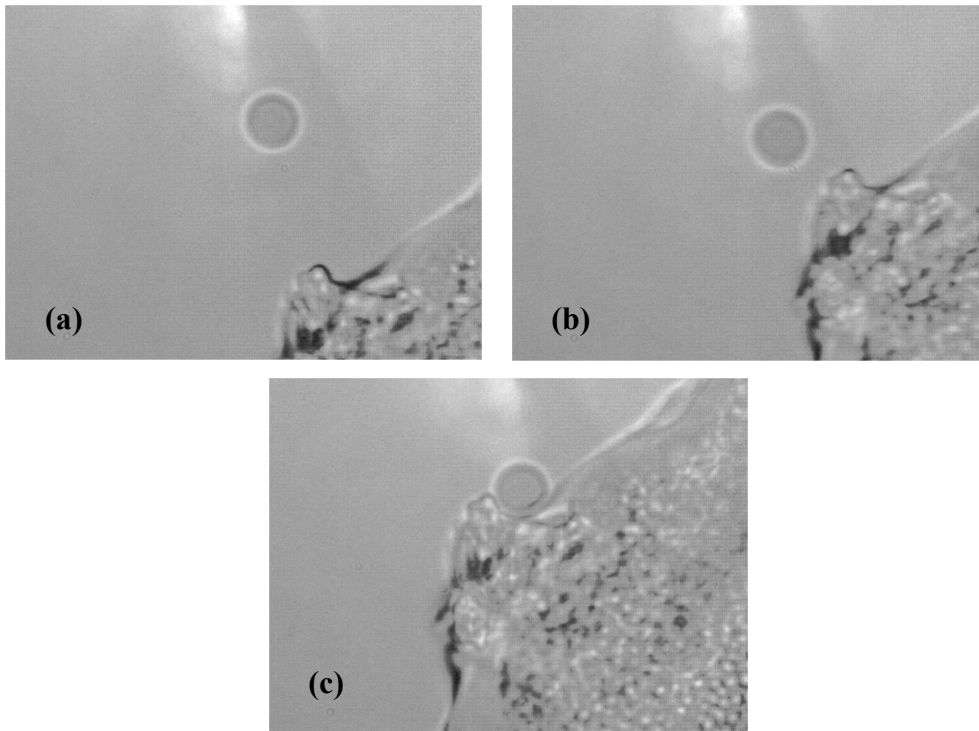

Fig. 10: Optical trapping sequence of a $5\mu\text{m}$ silica bead in water, $\sim 100\text{mW}$. Stronger filter in the camera allows the removal of the trapping laser from the image.

4 Future Work

An essential upgrade to the optical trapping set up is the integration of the SLM seen in **Fig. 2**. As this is a reflective element it should be possible to replace one of the turning mirrors with this device, however there are issues with filling the whole of the SLM surface and the angle of incidence (a small angle of incidence is preferable). This will give the ability to trap multiple objects and potentially bring them together. It is the intention of this research programme to investigate the engineering potential of micro-fabrication employing optical tweezers with new applications areas in abundance. One possibility available for discussion is introducing a second laser to consolidate or fuse particles together. It may also be possible to trap metallic particles with advanced trapping geometries (discussed earlier) only possible with the SLM. All proposed ideas for work in this area are currently tested before committing to any changes in set-up by modelling using Finite Difference in Time Domain (FDTD) methods to simulate the laser material interaction. The ability to independently and dynamically control many trapping sites and hence dielectric particles will be a powerful tool for the manipulation of objects that cannot be trapped easily. The ability to interact with a micro or potentially a nano sized object offers the capability of micro/nano assembly. The optical trapping kit being developed by NWLEC will offer not only the capability to perform the more standard optical trapping services in say the bioscience area, but also offers ground breaking research potential.

Conclusions

A comprehensive introduction, explanation of theory and state of the art review of the optical trapping process has been given in this paper. Preliminary results from optical trapping experiments undertaken by the North West Laser Engineering Consortium were also presented, demonstrating the capability of the process for accurate non-contact micro-manipulation and or micro-assembly of components without any physical damage. Once complete the optical trapping kit being developed by NWLEC will be a great asset to the consortium, offering not only the capability to perform the more standard optical trapping services in say the bioscience area, but also offers ground breaking research potential.

Acknowledgements

The authors gratefully acknowledge the support of the North West Development Agency (NWDA) in the UK. More information on the North West Laser Engineering Consortium (NWLEC) at www.nwlec.org.uk.

References

- [1] Ashkin A et al: Observation of a single-beam gradient force optical trap for dielectric particles. In: Optics Letters 11(1986).
- [2] Neuman K C;: Optical trapping. In: Review of Scientific instruments 75 (2004).
- [3] Hansen P. M. et al: Expanding the Optical Trapping Range of Gold Nanoparticles. In: Nano Lett. 5 (2005)1937-1942.
- [4] Dholakia K; Reece P; Optical micromanipulation takes hold. In: NanoToday 1 (2006).
- [5] Ashkin, A.; Dziedzic, J. M.: Stability of optical levitation by radiation pressure. In: Appl. Phys. Lett. 24, (1974) 586.
- [6] Grier, D. G.: A revolution in optical manipulation. In: Nature 424 (2003) 810-816.
- [7] Leach J. et al: 3D manipulation of particles into crystal structures using holographic optical tweezers. In: Optics Express 12, (2004) 220-226.
- [8] Whyte G et al: An optical trapped microhand for manipulating micron-sized objects. In: Opt. Exp. 14, (2006) 12497-12502.
- [9] Volke-Sepulveda, K., et al.: Orbital angular momentum of a high-order Bessel light beam. In: J. Opt. B 4, (2002) S82.